

RF Series Water Softeners

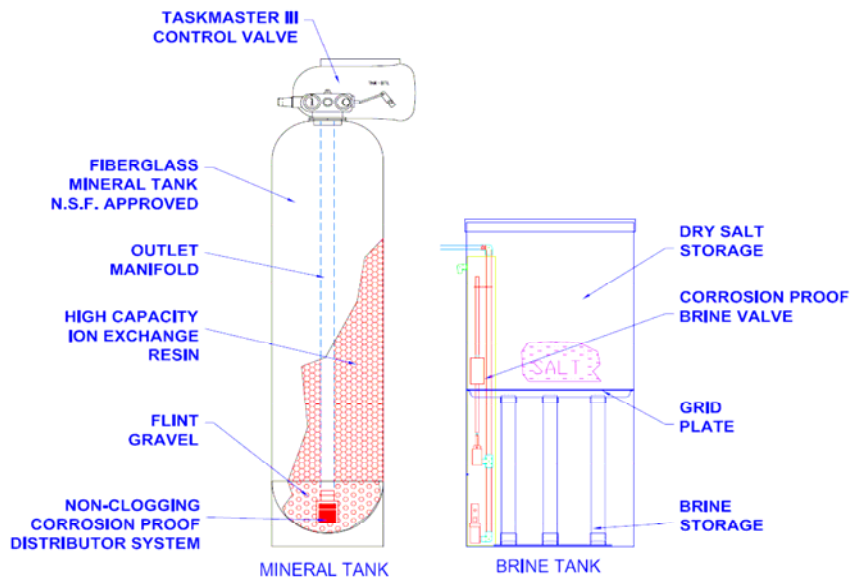

STANDARD FEATURES

TASK MASTER III™ - 1½" VALVE – TOP MOUNT

ERCt ELECTRONIC TIMER

POLYGLASS MINERAL TANKS

ACCUMATIC™ BRINE SYSTEM.

RESIN POLYSTYRENE 8% DVB CL

SINGLE POINT ABS DISTRIBUTOR

110V, 60Hz, 1Ø

OPTIONAL FEATURES

TWIN CONFIGURATION

TWIN ALTERNATING WITH ERCd AND PW SERIES METER

SHUT OFF KIT (SOK) TO PREVENT

BYPASS DURING REGENERATION

PRESSURE GAUGE AND TEST TAP KIT

SKID MOUNTING

220V, 50Hz, 1Ø

OPERATING CONDITIONS

25 TO 125 PSI ♦ 120°F

RF SERIES APPLICATION TABLE

Model ¹	50	70	100	120	150	240	300	450	600	750
Mineral Tank	12x52	13x54	14x65	16x65	21x62	24x72	30x72	36x72	42x72	48x72
Resin Volume (ft ³)	1 ½	2 ¼	3 ¼	4	5	8	10	15	20	25
Gravel (lbs)	15	30	40	55	140	200	250	300	700	1000
Brine Tank	18x40	18x40	24x40	24x40	24x40	24x50	24x50	30x50	39x60	39x60
Salt Storage (lbs)	320	320	570	570	500	640	640	900	2000	2000
Brine Valve (in)	¾	¾	¾	¾	¾	¾	¾	½	½	½
Capacity (Kgr)	49	69	100	120	153	232	293	432	594	731
Salt per Regen (lbs)	29	29	51	51	66	91	91	145	244	244
Continuous Flow ² (gpm)	15	23	32	40	50	56	60	62	63	63
Peak Flow ³ (gpm)	23	34	49	60	71	74	79	80	81	82
Backwash Rate ⁴ (gpm)	4	4	5	6	10	15	25	35	50	60
Height ⁵ (in)	59	61	72	72	73	80	86	90	90	101
Depth (in)	18	18	24	24	24	24	30	36	42	48
Width (in)	36	43	44	46	51	54	60	72	87	93
Twin Width ⁶ (in)	54	62	64	68	78	84	96	114	135	147
Single Weight (lbs)	300	350	420	495	665	925	1095	1395	1645	2500
Twin Weight ⁶ (lbs)	440	565	705	845	1185	1380	2115	2625	2825	5000

CAT211.2

1. Capacities are based on 20 gpg hardness at intermittent flow rates and are 95% of laboratory results.
2. Continuous flow rates are based on 10 gpm per cubic foot of mineral or a 15 psi pressure drop at 68°F, whichever is less.
3. Peak flow rates are based on 15 gpm per cubic foot of mineral or a 25 psi pressure drop at 68°F, whichever is less.
4. Drains must be able to dispose of water at the listed rate for up to 20 minutes.
5. Dimensions listed are actual unit height. Add at least one foot for loading mineral tanks.
6. A twin unit includes two mineral tanks and one brine tank.

RF SERIES DIMENSIONS

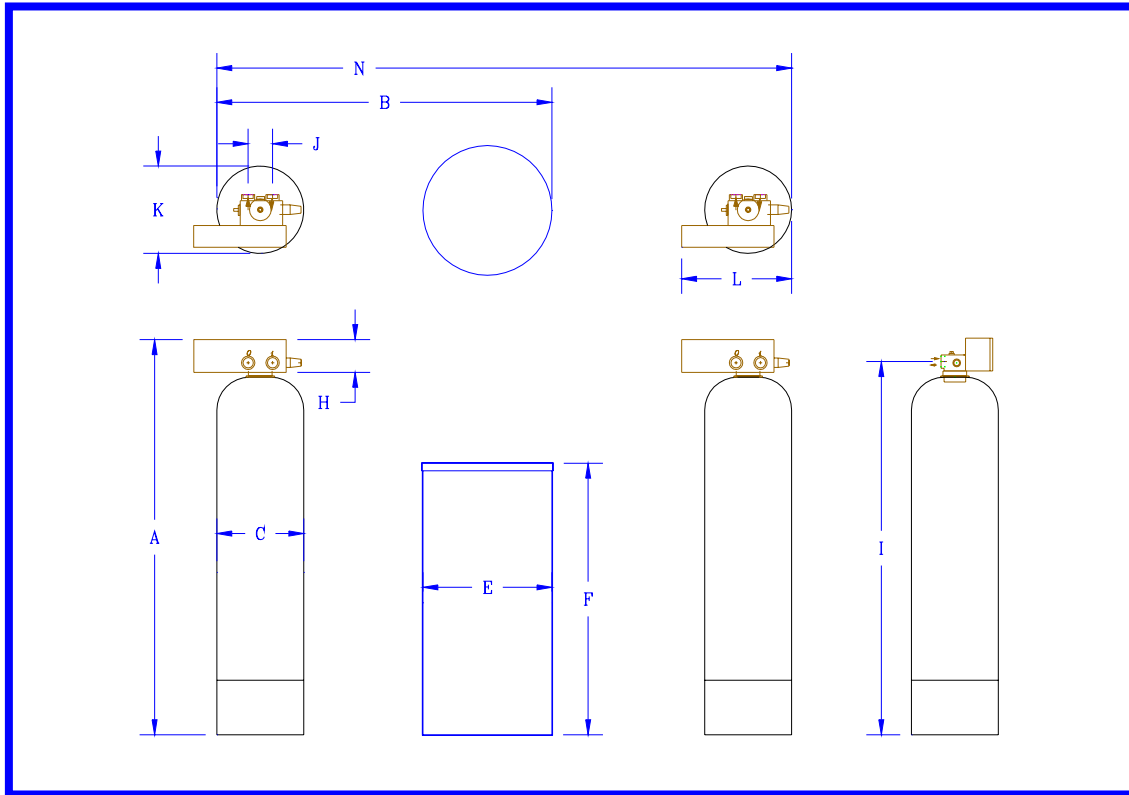

NOTE: A – HEIGHT⁵, E – DEPTH, B – SINGLE WIDTH, N – TWIN WIDTH⁶
SPECIFICATIONS LISTED ARE NOT SKID MOUNTED SYSTEMS.
SKID DIMENSIONS GIVEN UPON REQUEST.

RF SERIES DIMENSIONS - INCHES

Model	A	B	C	E	F	H	I	J	K	L	N
50	59	36	12	18	40	6 ½	54 ¼	4 ½	12	18	54
70	61	43	13	24	40	6 ½	56 ¼	4 ½	13 ½	18	62
100	72	44	14	24	40	6 ½	67 ¼	4 ½	14	18	64
120	72	46	16	24	40	6 ½	67 ¼	4 ½	15	18	68
150	69	51	21	24	40	6 ½	64 ¼	4 ½	17 ½	18	78
240	78	54	24	24	50	6 ½	73 ¼	4 ½	19	18	84
300	82	60	30	30	50	6 ½	74 ¼	4 ½	30	18	96
450	96	72	36	36	48	6 ½	74 ¼	4 ½	36	18	114

RF SERIES DIMENSIONS - CENTIMETERS

Model	A	B	C	E	F	H	I	J	K	L	N
50	159.9	94.4	30.5	45.7	101.6	16.5	138.4	11.4	30.5	45.7	137.2
70	154.9	109.2	33.0	61.0	101.6	16.5	142.9	11.4	34.3	45.7	157.5
100	182.9	111.8	35.6	61.0	101.6	16.5	170.8	11.4	35.6	45.7	162.6
120	182.9	116.8	40.6	61.0	101.6	16.5	170.8	11.4	38.1	45.7	172.7
150	175.3	129.5	53.3	61.0	101.6	16.5	163.2	11.4	44.4	45.7	198.1
240	198.1	137.2	61.0	61.0	127.0	16.5	186.1	11.4	48.3	45.7	213.4
300	208.3	152.4	76.2	76.2	127.0	16.5	188.6	11.4	76.2	45.7	243.8
450	243.8	182.9	91.4	91.4	121.9	16.5	188.6	11.4	91.4	45.7	289.6

RF Series Specification

Mineral Tank. The mineral tank shall be "polyglass" consisting of an inner shell of virgin polyethylene and an external shell of continuous fiberglass roving. Tanks shall be rated at 150 psi operating pressure, 120°F operating temperature with 4"-8 UN threaded top opening.

Internals. The distributor shall be a 2½" Ø single point molded distributor head with 2½" of slotted length and a 1½ inch female socket welded connection. The slots shall be 0.012" - 0.016" wide to retain mineral and the total slot area shall be equal to or larger than the unit pipe size. The distributor pipe shall be 1½" schedule 40 white PVC.

Media. The resin shall be sodium form polystyrene 8% divinyl benzene cross linked resin with clear spherical beads. Resin beads shall be 16-50 US Standard Mesh with a particle size range of 0.3 to 1.2 mm. The resin shall be clean and packaged in sealed plastic bags weighing 55 lbs or less.

Underbedding. The bottom of this mineral tank shall be filled above the distributor with #20 graded washed flint gravel sieved between 1/8" and 1/16".

Brine System. The brine system shall be of the Accumatic™ high grid plate design. The brine tank shall be blow molded or rotationally molded HDPE, including a cover. The system shall include a SCH 80 PVC float operated brine valve to control refill shut-off and refill flow rate. Brine volume is to be repeatedly accurate within 10% and not dependent on salt bed void space for brine volume. Brine draw is to be volumetrically controlled, not timed.

Control Valve Specifications. The main control valve(s) shall be the Task Master III™ with electronic controller to actuate the cycles of backwash, brine, slow rinse, fast rinse, and service for a water softener (or backwash, rinse and service for a filter). The control valve(s) shall be Task Master III™ 5-Cycle, multi-port control valve(s) with machined passivated CF8M Type 316 Stainless Steel body, Type 316 Stainless Steel piston assembly, and EPDM (NSF61 and WRAS Approved) inserts and seals with electronic controller and drive motor assembly in a NEMA 4/IP65 Style Enclosure. The valve shall operate with a single motor driven piston positioned by optical sensors. Valve inlet and outlet shall be 1 ½" FNPT. Backwash drain shall be ¾" or 1 ½" depending on flow. The brine inlet shall be ½". The one-piece brine eductor shall be installed in the valve. The valve shall be equipped with threaded ¼" FNPT ports for the installation of sample taps and pressure gauges. (Taps and gauges are optional.) Hard water by-pass shall be available during all regeneration cycles at 70 gpm or at the peak flow rate of the unit, at a pressure drop less than 25 psi, whichever is less. No hard water bypass option is obtained by adding a shut off kit to the valve. The valve shall be of a single piston design and shall not use multiple plungers or diaphragm valves. Maximum rated power shall be 125 watts with available current options of 115 VAC, 230 VAC, 100 VAC, 200 VAC, in 50 or 60 Hertz.



RF-100-TA with Optional Skid Mounting

CAT211.4

Ambient operating temperature range shall be 34°F (1°C) to 150°F (65°C). Fluid temperature range shall be 34°F (1°C) to 180°F (82°C). Operating pressure range shall be 20-125 psi (1.38 - 8.6 bar). The valve shall have UL, CSA, TÜV and CE certifications. ANSI/NSF 61 certification is pending.

Simplex (-SX). Simplex systems shall have regeneration initiated by time of day or "clock time". SX systems shall have one brine tank, one Task Master III™ control valve, and one ERCT controller. Ordering an optional shut off kit will prevent hard water bypass.

Simplex Meter Systems (-SM). Simplex-metered systems shall have regeneration initiated by gallons treated (demand). SM systems shall have one brine tank, one Taskmaster III™ control valve, one ERCd controller, one PW, PWS or TM series flow meter and two shut off kits (one for each vessel). The ERCT shall provide regeneration initiation and meter display. Ordering an optional shut off kit will prevent hard water bypass.



Twin (-T). Twin systems shall consist of two mineral tanks with attached Task Master III™ control valves and one brine tank with a brine director. Regeneration initiation shall be by an ERCT time initiated electronic regeneration controller operating in 6-day or 7-day mode.

Twin Alternating (-TA). Twin alternating units operate so that once a predetermined amount of water has passed through the flow meter the ERCd initiates regeneration of the exhausted unit placing its twin in service. One unit is on line and one is either in standby or service. The ERCd demand initiated regeneration controller controls the regeneration cycles for both of the twin alternating units. TA systems shall have two mineral tanks, two Task Master III™ control valves (a primary and a secondary), one brine tank with brine director, one ERCT controller, one PW, PWS or TM series flow meter and two shut off kits. The ERCT shall provide regeneration initiation and meter display.

System Operating Conditions. Maximum temperature shall be 120°F. Maximum Pressure shall be 125 psi. The temperature rating can be raised to 150°F by specifying Viton seals for the shut off kits (-V), vinyl ester resin for the mineral tanks, and 10% DVB cross-linked resin as the media.

Other items. A standard soft water soap test kit shall be provided. A complete set of instructions, including installation, loading, start-up, adjustments, servicing, and a parts list shall be provided with the equipment.

Qualifications. A company that has continuously manufactured water softeners for at least twenty (20) years shall construct this equipment.

Shut off kit. Hard water bypass during regeneration shall be prevented by a shut off kit to include a cast iron body diaphragm valve (DM Series) and a three-way solenoid valve with wiring and conduit to connect to Task Master III™.

Pressure gauge and test tap kit. A kit containing two liquid filled, stainless steel pressure gauges with 2 1/2" Ø face, two brass ball valve sample taps with hose barb connections and associated brass connection fittings shall be provided for mounting in the 1/4" FNPT predrilled and tapped ports in the inlet and outlet of the Task Master III™ valve.

