

# Automatic Strainers

ASME Section VIII, Div 1,  
Current Edition:  
U and UM CODE STAMP  
Available

## The Eliminators

The Eliminator, motorized, automatic, self-cleaning strainer, provides continuous debris removal from fluid piping systems that demand full time uninterrupted flow.

The Eliminator is particularly effective in fluid applications where unattended service, high solids loading and/or uninterrupted flow requirements deem a basket strainer and its attendant maintenance problems impractical.

Any of the 700 Series Strainers, applied correctly, will prove efficient and cost effective compared to simplex/duplex strainers or other automatic straining systems.

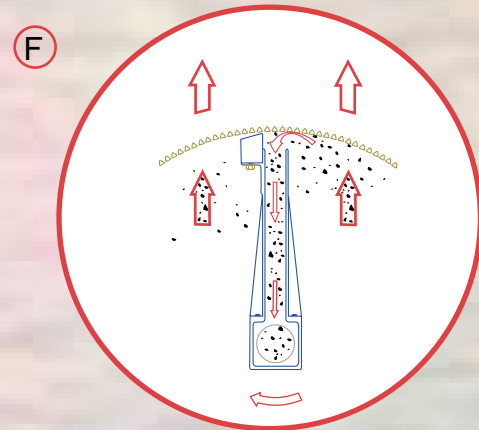

Port/straining element interface during backwashing cycle.

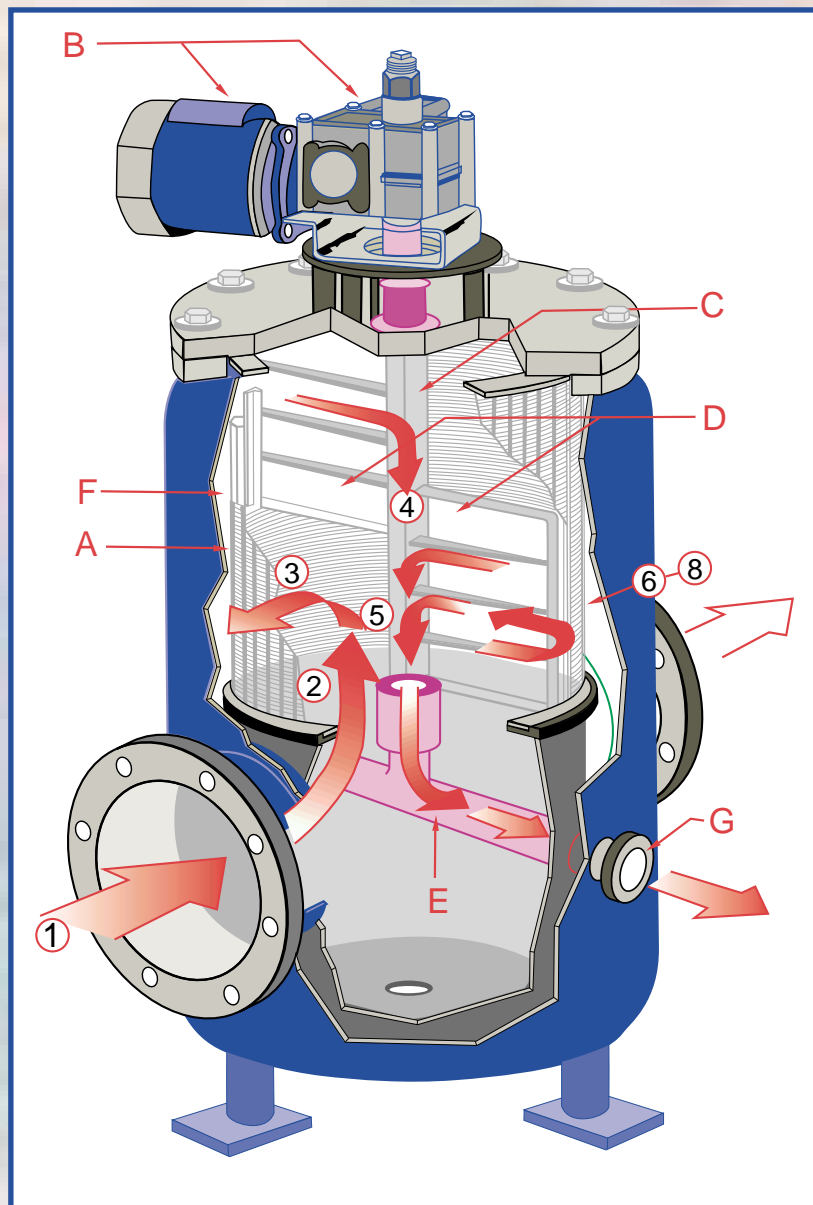

Figure 1 - Cut-away of Eliminator showing fluid flow during operation

## Sequence of operation

1. Debris laden fluid enters through inlet to inner chamber. (Fig. 1)
2. Dirty fluid flows upward and outward through the strainer element (A).
3. Debris is retained on the flat face of the strainer element, while strained fluid continues to outer chamber and exits through strainer outlet. (See inset)
4. During backwash or cleaning cycle, the motor/gear reducer (B) is engaged and drives the hollow drive shaft (C) and hollow port (D) around the inner circumference of the strainer element.
5. The backwash assembly (E) is opened to atmospheric pressure by opening the backwash control valve (not shown).
6. Flow reversal occurs at the port/straining element (F) interface because of the pressure differential described in 5.
7. Debris is effectively vacuumed from the full length of the straining element by a vigorous reverse fluid flow and into the hollow port; down the hollow drive shaft and out the backwash outlet (G).
8. The hollow port continues to sweep the full length of the strainer element until the cleaning cycle has ended.
9. The strainer will provide continuous uninterrupted fluid flow during the cleaning operation.
10. The cleaning cycle can be set for continuous or intermittent backwash.

# Automatic Self-Cleaning Strainers



Figure 2 - Wedge Wire Straining Element Cross-Section

## Application

The Eliminator's patented unique strainer element design permits installation in virtually any piping system operating at a positive pressure.

The Eliminators can operate through a wide range of operating pressures (5 psig minimum) and solids loading with effective debris removal and backwashing across the entire pressure range. Additionally, only one drain/backwash connection is required for installation, effectively eliminating the expense of a separate backwash pressure connection.

Strainers are used to protect equipment such as valves, pumps, meters, heat exchangers or spray nozzles, as well as in-feed water and process water applications or virtually any similar application.

The Eliminator 700 Series Automatic Self-Cleaning Strainers are fabricated in pipe sizes ranging from 1" to 48" to suit most application requirements.

## Proven Features Include:

- Patented rugged screen and mechanical assist backwash mechanism extends useful service life.
- Unique clog-resistant straining element reduces maintenance downtime.
- All internal replacement parts supplied in corrosion resistant material.
- Efficient new design reduces maintenance requirements; requires fewer parts.
- Low rpm backwash mechanism provides more efficient cleaning, less wear of internals.

## Straining Element

The Eliminators feature a revolutionary reverse rolled wedge-wire straining element (Fig. 2) that is extremely rugged and more clog-resistant than conventional strainer elements that use perforated plate or wire mesh screens.

This proven state-of-the-art straining media is fabricated by wrapping vertical rods with wedge shaped profile wire. Each intersection of rod and wire is welded to produce an extremely rugged one-piece element. This forms a continuous slot that allows only two point contact with debris particles to reduce clogging.

The wedge shaped profile wire reduces the possibility of retaining debris smaller than the screen opening which historically has been the cause of premature clogging or failure of competitive screen designs.

## Advantages of Wedge Wire Straining Element

- Maximum effective flow area and maximum operating efficiency are maintained throughout service life.
- Maintenance costs are reduced drastically due to reduced clogging and stappling of fibrous material.
- Long-lived straining element provides reduced operating costs over entire service life.
- Rigid element prevents flexing which can cause premature element failure.
- Efficient, effective debris collection at media/screen interface.

# Strainer Element Selection



Figure 3 - Wedge-Wire Straining Elements

## Straining Element Selection

The 700 Series Straining Element (Fig. 3) is an extremely rugged, single-piece unit available in a variety of standard and custom openings and materials.

Screen opening should be selected based on the amount of protection necessary, and not on the smallest opening available. By specifying a smaller opening than needed, more debris will be retained

and subsequently result in longer cleaning durations and increased backwash fluid loss. Also, smaller than necessary screen openings will reduce open screen area and increase pressure loss.

The screen opening should be approximately one-third (1/3) to one half (1/2) the largest size particle that can safely pass downstream. Example: A strainer protecting spray nozzles with a 1/16" orifice would be supplied with a 1/32" screen opening.

## Straining Element Selection Guide

Slot Opening (inches)	Fraction Equivalent inches (mm.)	Mesh Equivalent	Micron Equivalent	% Open Area	Slot Opening (inches)	Fraction Equivalent inches (mm.)	Mesh Equivalent	Micron Equivalent	% Open Area
<b>Standard</b>					<b>Custom</b>				
0.015	1/64 (0.4)	40	385	24	0.003	- (0.08)	200	75	9
0.031*	1/32 (0.8)	20	795	40	0.006	- (0.15)	100	149	16.5
0.062*	1/16 (1.6)	10	1590	51	0.010	- (0.25)	50	250	17.5
0.125*	1/8 (3.2)	6	3205	67	0.020	- (0.5)	35	500	30
0.187	3/16 (4.8)	4	4795	72	0.040	- (1.0)	18	1000	46
					0.156	5/32 (4.0)	5	4000	69
					0.250	1/4 (6.4)	3	6410	78

\* Available from stock

Standard screen material is 304 Stainless Steel.

316 Stainless Steel, 316L Stainless Steel, Monel and other materials are available upon request.

# The Hyper-Jet<sup>®</sup> Advantage

## The Hyper-Jet™

The Hyper-Jet™ is the line of motorized, automatic self-cleaning strainers. It is very effective in system applications where operating pressure is low (under 5 psig) or where the debris is difficult to remove. The 721 Series strainer provides unattended service with the addition of external backwash to enhance the self-cleaning attribute over other automatic strainers.

### Application:

The Hyper-Jet™'s unique patented backwash system permits installation in a broader range of applications. This range includes from relatively low pressure to very high pressure and from coarse, easily removed debris to fine, sticky debris.

In a low pressure mode (such as on the suction side of a pumping system), the Hyper-Jet™ system is mounted on the leading edge of the strainer backwash arm. External fluid is directed at an incident angle over the inside surface of the straining element through the high pressure nozzle assembly. The high velocity of this spray assists the cleaning of the straining element. **External source backwash pressure must be a minimum of 30 psi over operating pressure.**

Hyper-Jet™ strainers are used to protect equipment such as pumps, motors, heat exchangers or spray nozzles, as well as process applications such as cooling towers or virtually any similar application.

The Series 721 Hyper-Jet™ Self-Cleaning Strainers are fabricated in pipe sizes ranging from 1" to 36" to suit most applications' requirements.

The Hyper-Jet™ System can also easily and economically be field installed in any Fluid Engineering Self-Cleaning Strainer (6" size and larger) in service as a retrofit installation.

## The Unique Hyper-Jet™ Advantage

The external source of backwash fluid is introduced by opening the control valve (not shown) connecting the spray nozzles (A) at the leading edge (B) of the backwash assembly.

A "Jet" spray action occurs at the straining element inside surface (see insert) in addition to the flow reversal at the port/straining element interface.

Debris is effectively removed from the full-length of the straining element by a vigorous "Hyper-Jet" fluid flow into the hollow port; down the hollow drive shaft and out the backwash outlet.



Figure 2 - The innovative internals of the Hyper-Jet™ showing ease of maintenance.

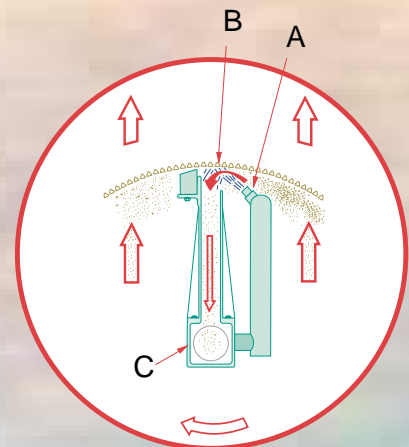

Cross-Sectional View of Port/Straining Element During Backwash Cycle

Series 721 Self-Cleaning Strainer Typical Backwash Flow Requirement										
Strainer Size	1", 1-1/2" 2" or 3"	4"	6"	8"	10/12"	14/16"	18/20"	24"	30"	36"
Backwash Line Size	1-1/2"	1-1/2"	1-1/2"	1-1/2"	2"	3"	3"	4"	4"	6"
Backwash Flow in GPM (Gal. Per Minute)	8-12	15-20	30-40	60-75	110-150	170-210	250-310	400-490	550-700	750-900
External Backwash Source GPM	3-5	3-5	5-10	10-15	15-25	25-35	35-45	55-65	80-90	115-130
External Line Size	3/4"	3/4"	3/4"	1"	1"	1"	1-1/4"	1-1/2"	1-1/2"	2"

# Specifications - Dimensions / Weight

## 793 Series 1" -10"

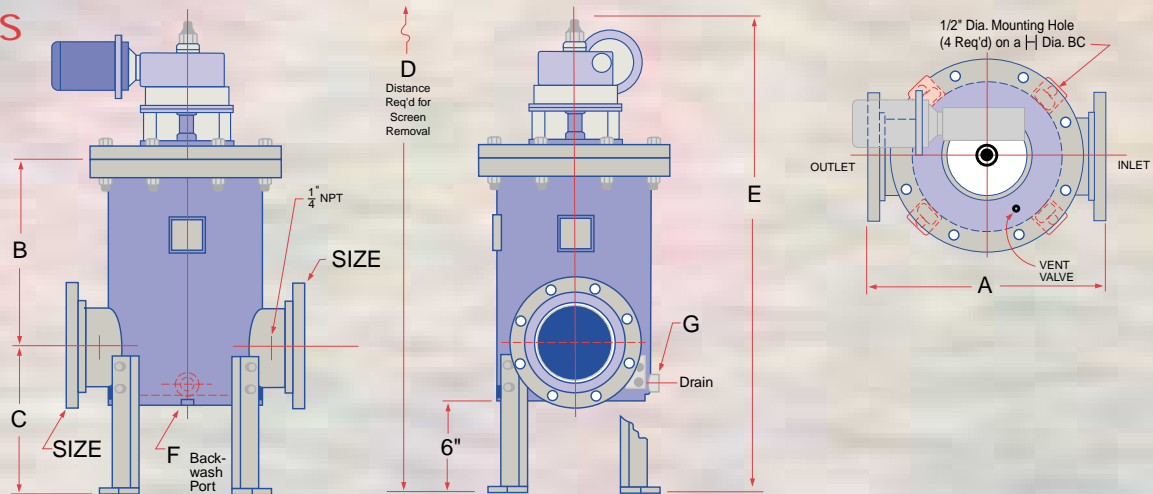

Model No.	Size (In.)	A (In.)	B (In.)	C (In.)	D (In.)	E (In.)	F (In.)	G (In.)	H (In.)	Approx. Dry	Wts. Wet	Lbs. Cov.	Motor H.P.
010-793	1-150	16-1/2	14-1/4	10	53	30-1/2	1 NPT	1 NPT	11-1/4	320	466	142	1/4
015-793	1 1/2-150	16-1/2	14-1/4	10	53	30-1/2	1 NPT	1 NPT	11-1/4	323	469	142	1/4
020-793	2-150	16-1/2	14-1/4	10	53	30-1/2	1 NPT	1 NPT	11-1/4	327	473	142	1/4
025-793	2 1/2-150	16-1/2	14-1/4	10	53	30-1/2	1 NPT	1 NPT	11-1/4	336	482	142	1/4
030-793	3-150	16-1/2	14-1/4	10	53	30-1/2	1 NPT	1 NPT	11-1/4	338	484	142	1/4
040-793	4-150	16-1/2	14-1/4	10	53	30-1/2	1 NPT	1 NPT	11-1/4	348	494	142	1/4
060-793	6-150	20	15-5/8	11	58-5/8	32	1-1/2 NPT	1 NPT	15-1/2	511	700	176	1/4
080-793	8-150	28	18	16	74	41	1-1/2 NPT	1 NPT	20-3/4	797	1030	200	1/4
100-793	10-150	28	18	16	74	41	1-1/2 NPT	1 NPT	20-3/4	830	1060	200	1/4

THREADED (NPT) INLET/OUTLET CONNECTIONS AVAILABLE

## 723 Series 10" -20"

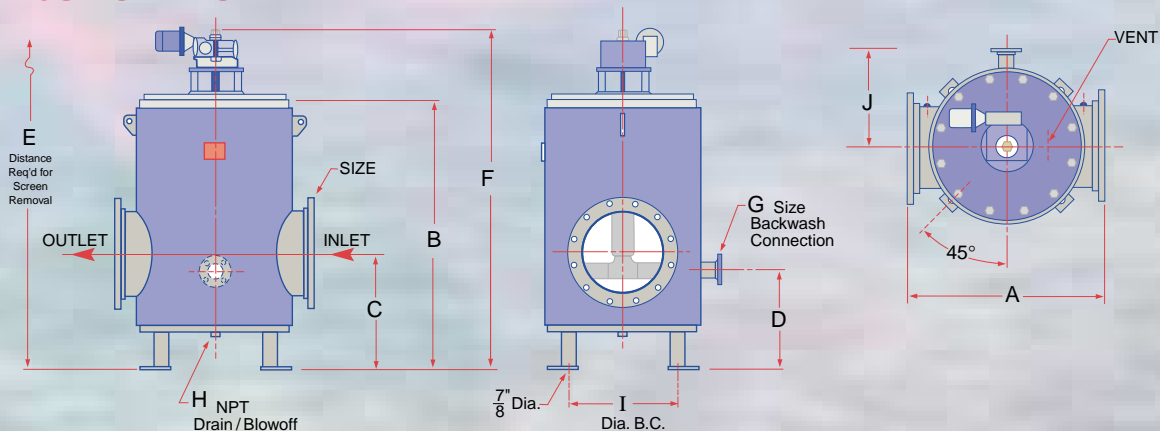

Model No.	Size (In.)	A (In.)	B (In.)	C (In.)	D (In.)	E (In.)	F (In.)	G (In.)	H (In.)	I (In.)	J (In.)	Approx. Dry	Wts. Wet	Lbs. Cov.	Motor H.P.
100-723	10-150	36	43	17 1/2	14 1/2	75	58 1/2	2 NPT	1 1/2 NPT	26	14 3/4	1450	2100	290	1/4
120-723	12-150	36	43	17 1/2	14 1/2	75	58 1/2	2 NPT	1 1/2 NPT	26	14 3/4	1520	2175	290	1/4
140-723	14-150	44	51 1/2	19 1/2	15 1/2	94	69	3-150	1 1/2 NPT	32	21 3/4	2375	3650	460	1/4
160-723	16-150	44	51 1/2	19 1/2	15 1/2	94	69	3-150	1 1/2 NPT	32	21 3/4	2450	3725	460	1/4
180-723	18-150	48	66	24	21	113	87	3-150	2 NPT	38	25 1/4	3290	5535	580	1/4
200-723	20-150	48	66	24	21	113	87	3-150	2 NPT	38	25 1/4	3375	5625	580	1/4

DIMENSIONS SUBJECT TO CHANGE WITHOUT NOTICE. APPLY FOR CERTIFIED DRAWINGS

# Specifications - Dimensions / Weight

## 723 Series 24" - 36"

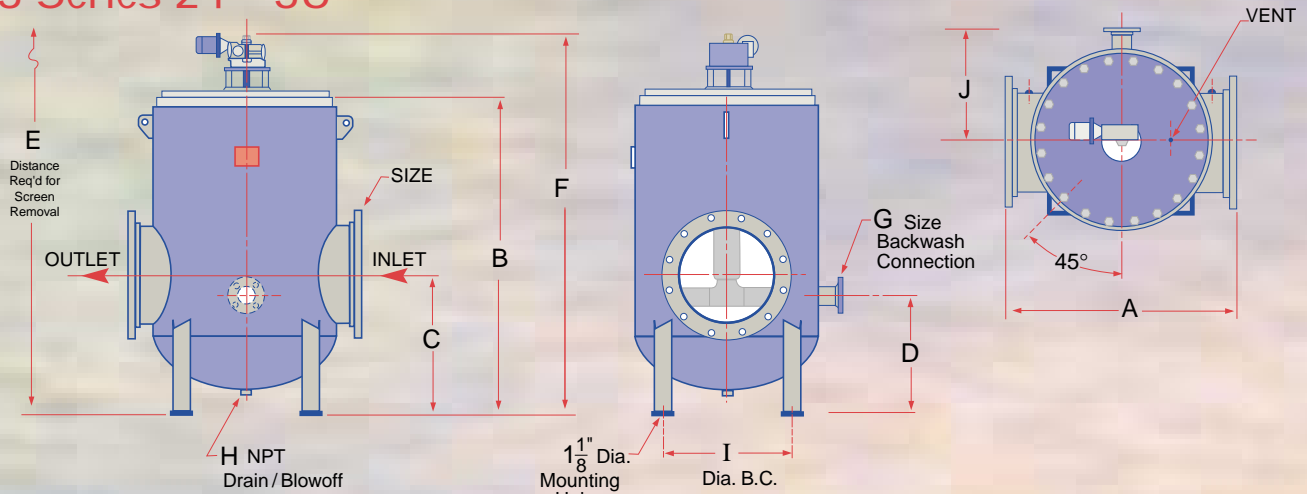

Model No.	Size (In.)	A (In.)	B (In.)	C (In.)	D (In.)	E (In.)	F (In.)	G (In.)	H (In.)	I (In.)	J (In.)	Approx. Dry	Wts. Wet	Lbs. Cov.	Motor H.P.
240-723	24-150	56	77	33	28	122	98	4-150	2 NPT	44	28	4,375	8,350	610	1/3
300-723	30-150	66	94	39	34	150	115	4-150	2 NPT	54	33	6,525	13,625	1,125	1/3
360-723	36-150	86	158-5/8	47-5/8	40-5/8	210	130	6-150	2 NPT	72	43	12,050	26,975	1,490	1/2

LARGER SIZES AVAILABLE UPON REQUEST  
DIMENSIONS SUBJECT TO CHANGE WITHOUT NOTICE. APPLY FOR CERTIFIED DRAWINGS

## Specifications - Pressure Drop Charts

### 721-723 Series

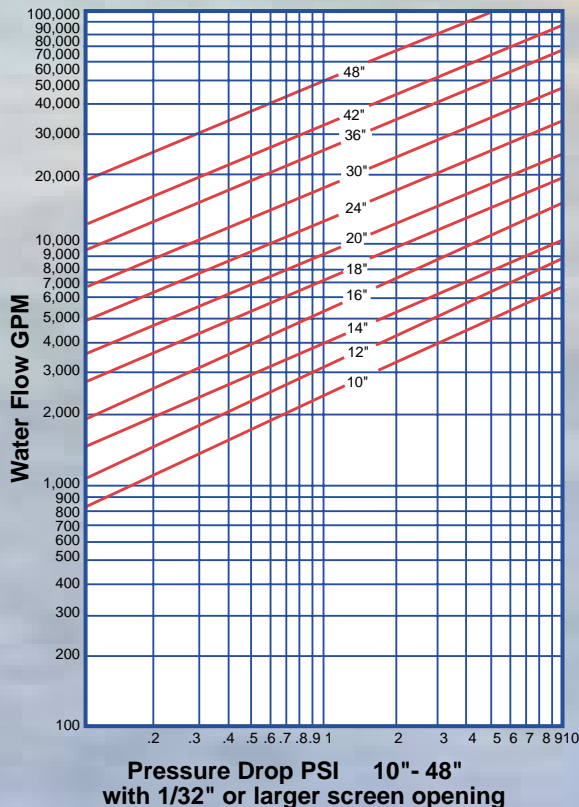

### 793 Series

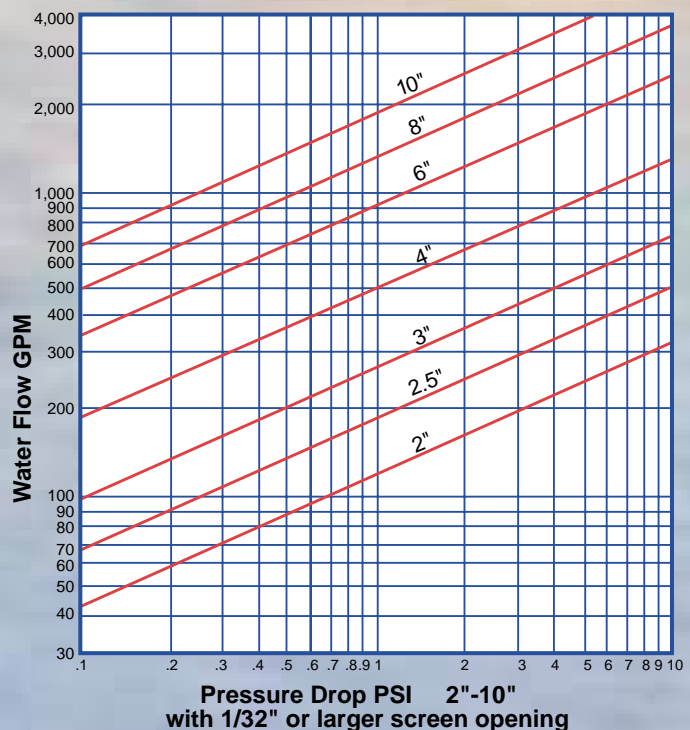

# Specifications and Options

## Typical Strainer Specifications

The strainer shall be Series 723/793 Self-Cleaning, motorized type. (Fig. 4)

The body and cover shall be fabricated (carbon steel), designed, manufactured and tested generally to ASME Section VIII Standards, using qualified ASME Section IX welders.

Housing to be suitable for a design pressure of (150) psig. Inlet and outlet connections shall be flanged and conform to ANSI B16.5 standards. The strainer shall have a single backwash connection and large drain connections located in vessel bottom. Unit to be complete with factory supplied steel support legs for bolting to concrete or steel base.

Strainer shall be \_\_\_\_\_ size capable of handling \_\_\_\_\_ gpm of fluid at a \_\_\_\_\_ psig pressure loss with clean straining elements.

The straining element will be manufactured from corrosion resistant (304 Stainless Steel) reverse rolled slotted wedge wire screen designed with \_\_\_\_\_ inch openings. The wide or flat cross section of the wedge wire shall face the direction of flow providing for a continuous smooth flat surface to trap debris. The straining media shall be free of pockets, tubes, collector bars, etc. that accumulate and trap debris permanently.

All internal parts will be of corrosion resistant (304 Stainless Steel). The strainer shall be provided with drive shaft and hollow port assembly fitted with all necessary bearings and seals.

The drive arm and hollow port assembly will be free running at a maximum speed of two (2) rpm and not contact with screen surface. Port assembly shall be factory and field adjustable for positive effective cleaning and shear capability. Note: Sizes 1" thru 20" have (1) backwash hollow port. Sizes 24" and up will have (2) backwash hollow ports.

Drive shaft will be supported at the top with roller bearings located in a double reduction gear reducer and at the bottom with a water lubricated guide bearing.

The gear reducer shall be driven by a \_\_\_\_\_ hp, \_\_\_\_\_ v, \_\_\_\_\_ Ph, 50/60 Hz, TEFC motor.

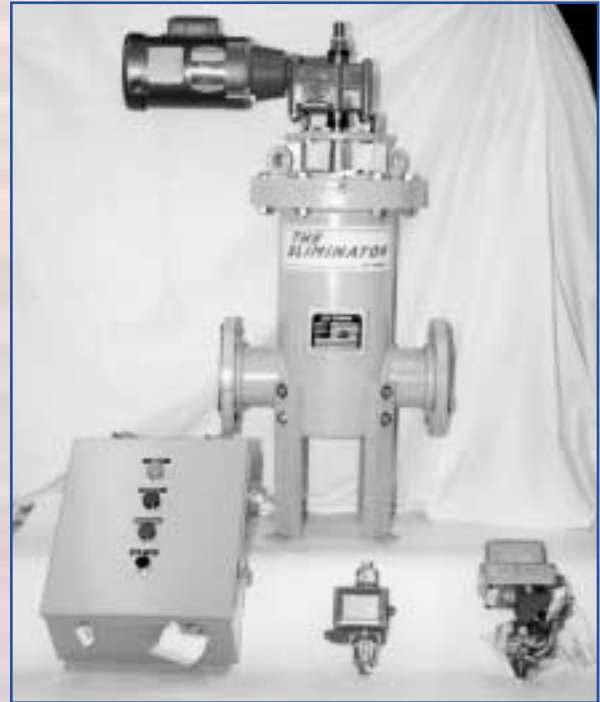

Fig. 4

## Strainer Options Available

- Cover Lift Assemblies -** Recommended for remote locations.
- ASME -** ASME Section VIII and Code stamped.
- Materials of Construction -** Consult factory for stainless steel, copper, nickel, monel, or other requirements.
- Control Package -** Control Panel with Nema 4 Enclosure, Backwash Valve with Electric Operator, Single Element Differential Pressure Switch.
- Design -** High Pressure applications - Consult factory.
- Hyper-Jet -** Low Pressure and Special Application.
- Skid Packages -** All equipment desired, including strainers, valves, controls, wiring, piping and skids may be combined as a complete, custom package. Size of the project has no limitation.
- Water Saver Package -** The Water Saver Package (Fig. 5) can be used on most applications where the strained liquid is scarce or valuable. The strainer backwash fluid is directed to a centrifugal separator where only a fraction of the strainer backwash is discharged to waste. The separator backwash can be manually operated and/or automated with a pre-set timer controlled valve.

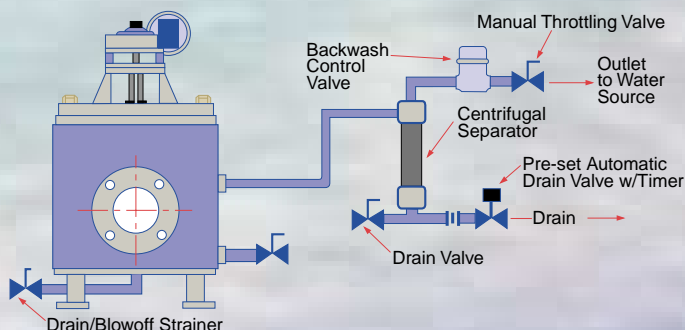

Fig. 5 - Series 723 - Water Saver Package

# Sequence Controller



## Design and Construction

The Sequence Controller is designed with the Customers' specific requirements in mind. The Sequence Controller provides an automatic, effective backwashing cycle with a minimum loss of water.

The Sequence Controllers are constructed with state-of-the-art industrial type components which permits replacing individual components without having to replace an entire circuit board. The industrial type components are more durable and reliable and adjustments can be made with ease.

## Standard Features

- Enclosure - Nema 4
- Adjustable Cycle Timer
- Off-delay Timer
- Motor Starters with Auxiliary contact and overload relay
- Selector Switch
- Indicating Lights
- Fuses
- Terminal Block

## Modes of Operation

There are basically two modes of operation - intermittent and continuous. By turning the selector switch, the mode of operation can be selected.

## Automatic Intermittent Position

With the selector in the "Auto" position, the drive motor will start and the backwash valve opens as determined by the adjustable cycle timer or by the differential pressure switch.

The differential pressure switch is normally factory set at 1 - 1-1/2 psig over the anticipated clean pressure drop. Should a high differential pressure occur during the timed off period, the differential pressure switch will override the cycle timer and start or continue the backwash until the differential pressure is satisfied. After the differential pressure has been satisfied, the strainer will continue to backwash for an additional 60 seconds (time delay relay).

The Automatic Self-Cleaning Strainer would start a backwash cycle based on the timed sequence selected on the adjustable cycle timer. The timed sequence should be determined by each

installation and the conditions experienced. The adjustable cycle timer can be programmed from 15 minutes to a 10-hour cycle (off) and for 1 to 10 minutes duration (on). Adjustments can be made as conditions warrant them.

## Continuous Operation

The selector switch is adjusted to "Manual" thus permitting the continuous mode. In the continuous mode, the Automatic Self-Cleaning Strainer will be backwashing continuously with the backwash valve open and the drive motor running. This mode of operation may be necessary if the installation experiences high solid loadings.

In either Mode of Operation, the backwash assembly is specifically designed to rotate at 2 RPM to allow for effective backwashing in less time, thus decreasing the amount of backwash water lost.

## Standard Control Package

The Sequence Controller Control Package consists of:

- Control Panel with Nema 4 Enclosure
- Backwash Valve with Electric Operator
- Single Element Differential Pressure Switch

## Options

- 230V, 380V, 460V, 575V
- 50 or 60 hertz
- Dual Element Differential Pressure Switch
- Nema 4X (Fiberglass or Stainless Steel), Nema 7 or 9 (Explosion Proof), Nema 12, Nema 3 Enclosures
- Circuit Breakers, Disconnect Switch, Transformer
- Reset Buttons
- Alarms
- PLC Interface and/or Pump Interlock
- Extra Contact and Relays
- Backwash valve can be supplied with Pneumatic Operator
- Backwash Valve available in numerous materials
- Differential Pressure Switches available with Mercury, Snap Action, Diaphragm or piston contacts.

## Codes/Standards

The Sequence Controller can be manufactured to UL Listings, CSA Approval, JIC, NEMA Standards.

# Sure Flow Equipment Inc. – Limited Warranty

All products are warranted to be free of defects in material and workmanship for a period of one year from the date of shipment, subject to below. **All custom products are not subject to return, credit or refund.**

If the purchaser believes a product to be defective, the purchaser shall:

(a) Notify the manufacturer **within ten(10) days after receipt of merchandise**, state the alleged defect and request permission to return the product. Merchandise will not be accepted for return without a "Return Code" clearly marked on the outside of the package. Contact the office to obtain a return code. **Merchandise will not be accepted for return or credit later than six (6) months after invoicing.**

(b) If permission is given, return the product with the transportation prepaid. Collect shipments will not be accepted. Goods must be returned **prepaid.**

If a shipment is received in a damaged or deficient condition, a claim must be filed with the delivering carrier and noted on the freight bill before you accept the merchandise. All other claims must be made in writing and received by Sure Flow Equipment Inc. within ten (10) days after receipt of merchandise.

If the product is accepted for return and found to be defective, the manufacturer will, at its discretion, either repair or replace the product, F.O.B. factory, within 60 days of receipt, or issue credit for the purchase price.

Sure Flow Equipment Inc. shall not be liable for failure to deliver or delays in delivering occasioned by acts of God, war, labor difficulties, inability to obtain materials or any other causes whatsoever beyond our control.

Other than to repair, replace or credit as described above, purchaser agrees that manufacturer shall not be liable for any loss, costs, expenses, or damages of any kind arising out of the product, its use, installation or replacements, labeling, instructions, information or technical data of any kind, description of product use, sample or model, warnings or lack of any of the foregoing.

NO OTHER WARRANTIES, WRITTEN OR ORAL, EXPRESS OR IMPLIED, INCLUDING THE WARRANTIES OF FITNESS FOR A PARTICULAR PURPOSE AND MERCHANTABILITY, ARE MADE OR AUTHORIZED. NO AFFIRMATION OF ACT, PROMISE, DESCRIPTION OF PRODUCT OR USE OR SAMPLE OR MODEL SHALL CREATE ANY WARRANTY FROM MANUFACTURER, UNLESS SIGNED BY THE PRESIDENT OF MANUFACTURER.

**CANCELLATIONS:** Cancelled orders will be subject to a charge of at least 35%.  
Cancelled custom orders will be subject to a charge of 100% of quoted price.

**MINIMUM BILLING: \$50.00 NET**

**SPECIAL DOCUMENTATION:** A charge will apply for non-standard, special documentation requests such as Material Test Reports (MTR's) and Certificates of Conformance (COC's).

## Catalogs Available from Sure Flow Equipment

