

TOP VIEW

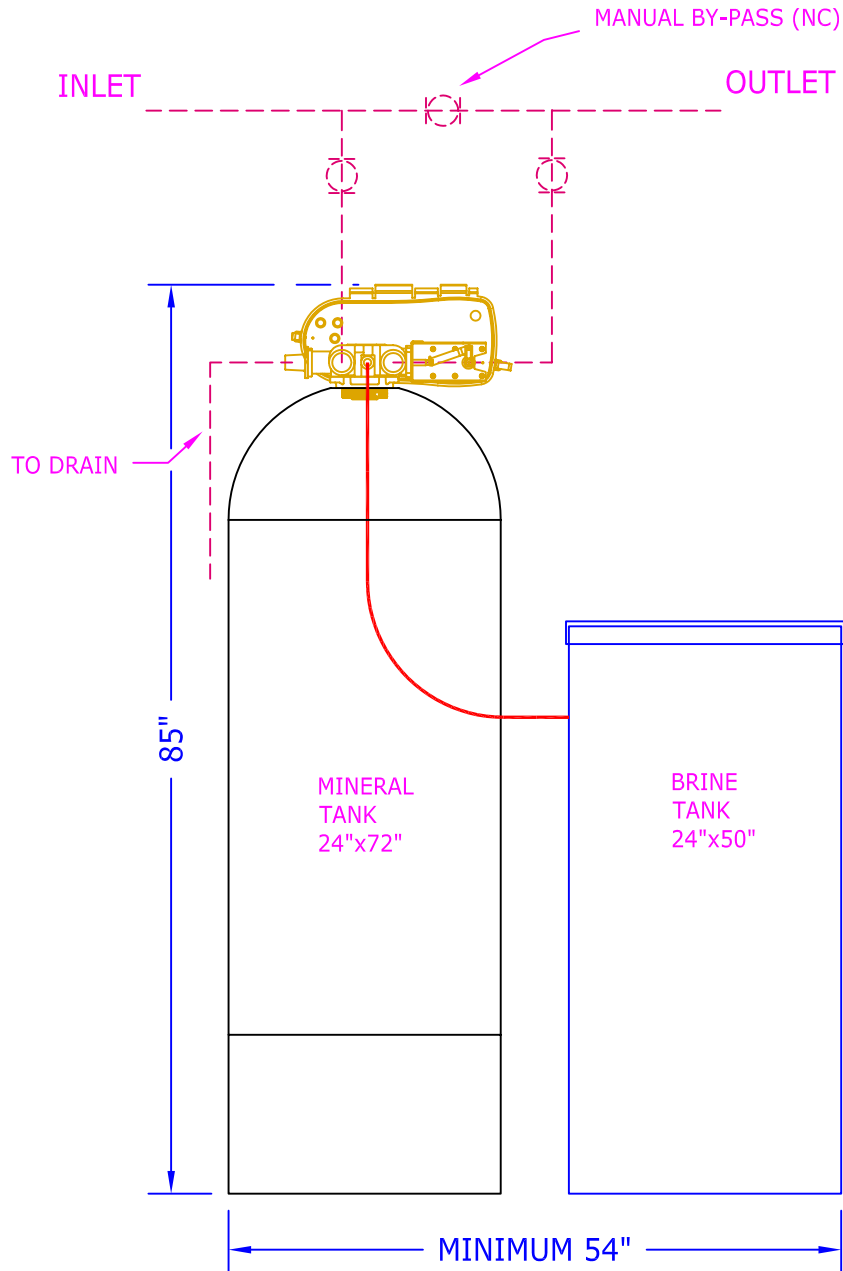

NOTES:

- 1) PIPING SHOWN IN DASHED LINES TO BE SUPPLIED BY CUSTOMER.
- 2) ALLOW 1 FOOT ABOVE TANKS FOR LOADING.

SHIPPING WEIGHT	925 Lbs.
OPERATING WEIGHT	

BY:	No.	REVISION	DATE	CK'D
RLR	0	SUBMITTAL FOR APPROVAL	03/28/2011	JEB
102 Charbonnet Rd., Duson, Louisiana, 70529, U.S.A.				



Telephone: (337) 988-2360 * Fax: (337) 981-7922

910240 RF-240 WATER SOFTENER GENERAL ARRANGEMENT		
SCALE	DRAWING NUMBER	SHEET
N.T.S.	RF-240-1,5-SX	01 / 01
www.waterking.com		