

Water King

Water King, Inc.

102 Charbonnet Rd., Duson, Louisiana, U.S.A. 70529

Telephone: (337) 988-2360 * Fax: (337) 981-7922

www.waterking.com

**NON-CODE WATER TREATMENT TANKS
EPOXY LINED & FINISH COATED IN WHITE EPOXY
NSF/ANSI STANDARD 61 CERTIFIED LINING
100 PSIG WORKING PRESSURE**

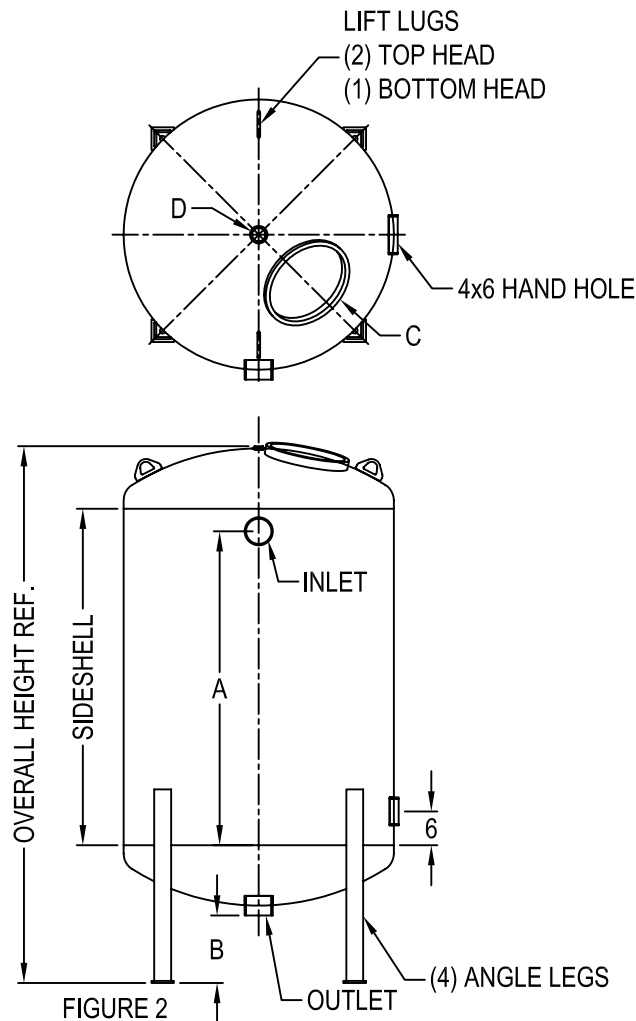

FIGURE 2

DIMENSIONAL CHART

DIAMETER	SIDE SHELL	A	B	INLET/OUTLET	C	D	OAH
48"	60"	55-3/4"	12"	4" NPT	12" X 16"	2" NPS	96"
	72"	67-3/4"					108"
54"	60"	55-3/4"	12"	4" NPT	12" X 16"	2" NPS	99"
	72"	67-3/4"					111"
60"	60"	55-3/4"	12"	4" NPT	12" X 16"	2" NPS	100"
	72"	67-3/4"					112"
66"	60"	55-3/4"	12"	4" NPT	12" X 16"	2" NPS	103"
	72"	67-3/4"					115"
72"	60"	55-3/4"	12"	4" NPT	12" X 16"	2" NPS	105"
	72"	67-3/4"					117"