

Bill of Materials List
by Location ID

Inventory ID	Description	Loc ID	Quantity	Unit	
					930564-5 BF-70-1"-SM IS SAME AS 930563-5 EXCEPT 1" VERSION INCLUDES 707140-4 1" ADAPTOR ALL PERFORMANCE DATA, SUBMITTALS AND DRAWINGS ARE THE SAME FOR BOTH 3/4" AND 1".
930563-5	BF-70-3/4"-SM W/ ERDd BAYOU SERIES WATER SOFTENER SIMPLEX METERED	1			
100046	13x54 POLY GLASS MINERAL TANK CONNECTION: 4"-8" UN TOP COLOR: BLUE	1	Item	1.0000	EA
100049	4" - 8 UN TO 2.5" - 8 NPSM ADAPTER	1	Item	1.0000	EA
703005	3/4" MANIFOLD ASSEMBLY 54" TANK 3/4" SCH 40 PVC PIPE 3/4" SLOTTED DISTRIBUTOR	1	Sub	1.0000	EA
479903	RESIN PK 70 13X54 F 2 1/4 , 0.30 2 1/4 FT3 8% CATION RESIN 30 LBS GRAVEL	1	Sub	1.0000	EA
805060	18X40 BRINE TANK ASSY BM/5SP BF BRINE TANK ASSEMBLY DIAMETER: 18 INCHES HEIGHT: 40 INCHES BLOW MOLDED HDPE TANK 4" BRINE WELL 3/8" TUBULAR BRINE VALVE W/ SAFETY CHECK	1	Sub	1.0000	EA
200126-5	5" HIGH POLYETHYLENE SALT PLATFORM BRINE LINE ASSEMBLY 3/8" BV 3/8" BL KIT CONSISTING OF 3/8" POLYPROPYLENE TUBING AND FITTINGS TO CONNECT PROFORMA VALVE TO 3/8" TUBULAR BRINE VALVE BF-30 THRU BF-70 SX AND SM SINGLE TANK SOFTENERS	1	Sub	1.0000	EA
707101-3-5	CTL PKG BF-70- 3/4" OR 1" W/ ERCd PERFORMA VALVE WITH: GLASS FILLED NORYL BODY INJECTOR: L BACKWASH: 4.1 GPM (NO 13) ERCd (762 LOGIX) CONTROLLER INTERNAL TURBINE FLOW METER 120 / 12 VAC ADAPTOR	1	Sub	1.0000	EA
707140-3	3/4" NPT ADAPTER KIT, ABS, BF LC ADAPTOR FOR PROFORMA VALVE SET OF TWO 3/4" MNPT REQUIRES ONE SET PER VALVE	1	Item	1.0000	EA
400903	2-1/2" FUNNEL	1	Item	1.0000	EA

End of Report

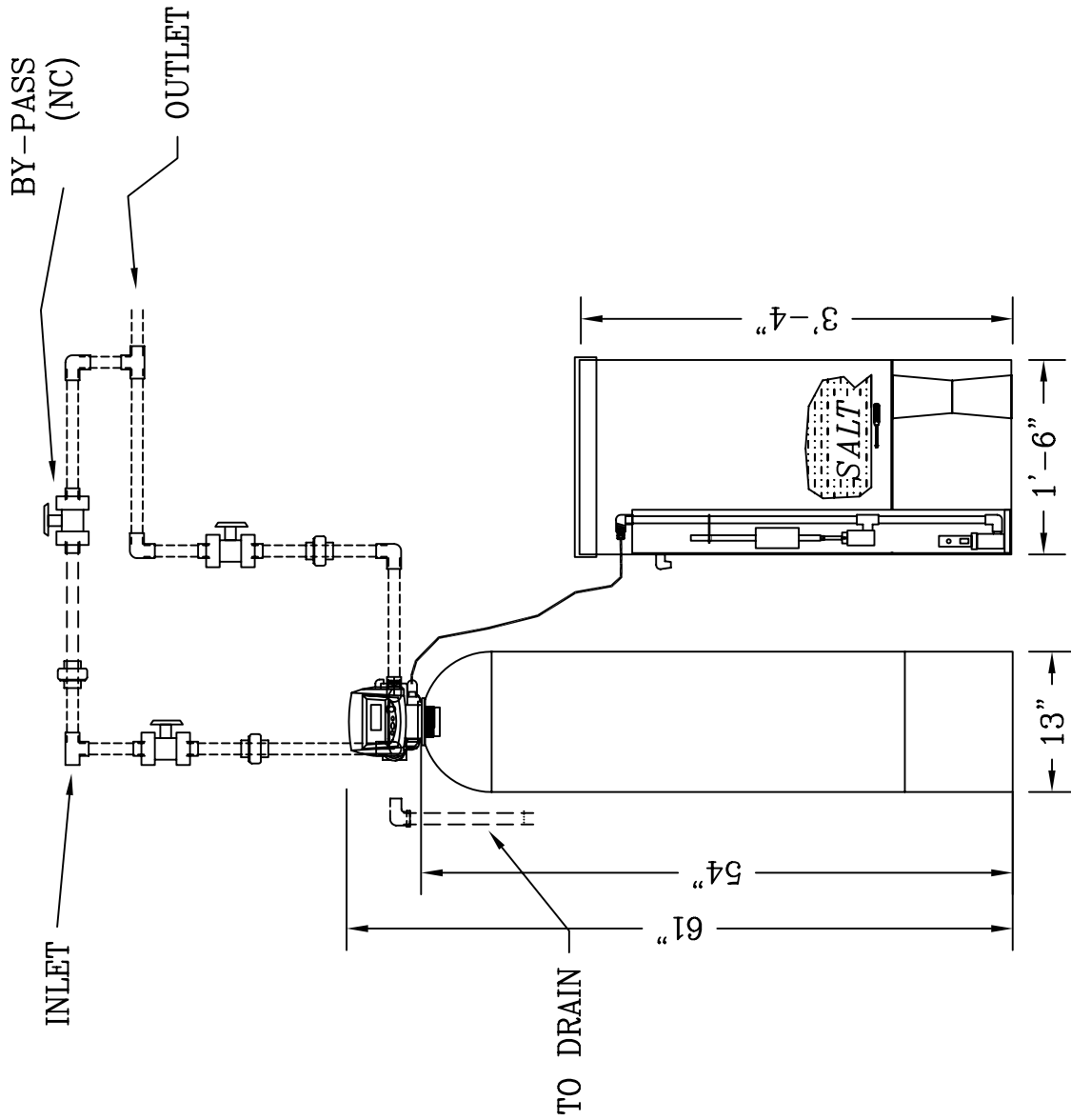

NOTE:

PIPING SHOWN IN DASHED LINES IS TO BE SUPPLIED BY CUSTOMER
ACTUAL LOCATION & LENGTH MAY VARY

BY: No.	REVISION	DATE	CKD
0	PRELIMINARY	9/30/06	
1	UPDATE BRINE TANK & CONTROL VALVE	9/24/07	

DR: R. RICHARDSON	ENG.: XXXX	DRY WEIGHT
BY:	FILE:	OPERATING WT.
CH:	C:\CATALOG\WKBF70SX.dwg	
DATE	DRAWING NUMBER	
SCALE	WKBFB70SX	
	NONE	

BF-70-SX TWIN ALT. WATER SOFTENER TYPICAL PIPING ARRANGEMENT		
Water King WATER CONDITIONING		
Water King, Inc. 102 Charbonnet Rd., Duson, Louisiana, U.S.A. 70529 Telephone: (337) 988-2360 * Fax: (337) 981-7922 www.waterking.com		
PLOTTED / PRINTED: 2009-06-02		SHEET 1 / 1



PERFORMANCE

Model BF 70 - 3/4" and 1" Simplex Water Softener Performance

Rated Continuous Flow:	21 gpm ($\Delta P = 15$ psi)
Rated Peak Flow:	28 gpm ($\Delta P = 25$ psi)
Head Loss	Flow
5 psi	11 gpm
10 psi	17 gpm
15 psi - continuous	21 gpm
20 psi	25 gpm
25 psi - peak	28 gpm
Capacity Per Vessel:	68,000 grains per vessel at 10 lbs salt per ft ³ resin
Brine Tank Salt Storage:	390 lbs
Brine Draw:	Timed brine system can be set by controller. Refill rate is 0.33 gpm.
Regenerations in Storage:	Assume 10 lb salt per ft ³ resin and 2 1/4 ft ³ resin gives 17 regenerations in storage.
Backwash Rate:	4.1 gpm

Simplex Timed (- SX). In simplex mode the system operates so that regeneration is performed automatically at a predetermined time of day or at a predetermined interval. The days of the week and time of day of regeneration is preset. The Logix controller controls the regeneration cycles for the softener and regeneration initiation. Simplex systems shall have one mineral tank, one Proforma valve, one brine tank, one Logix controller, and no flow meter (since regeneration initiation is based on time).

Simplex Metered (- SM). In simplex metered mode the softener operates so that once a predetermined amount of water has passed through the flow meter the Logix controller initiates regeneration. The Logix controller controls the regeneration cycles for the softener and regeneration initiation. Simplex systems shall have one mineral tank, one Proforma valve, one brine tank, one Logix controller, and one internal turbine flow meter.

During regeneration, the softener can be in bypass mode allowing hard water to bypass the softener OR it can be "shut off". If "shut off" the water to downstream equipment will be stopped. Hard water bypass is standard for single tank systems.

BF Simplex Water Softener



BF SERIES SPECIFICATION – Simplex Timed (-SX) and Simplex Metered (-SM)

BF. The BF series water softeners have composite (fiberglass tanks with polyethylene liners) with top mounted Performa™ glass filled Noryl control valves. These fully automatic softener packages consist of mineral tank(s) with resin (resin pack), Performa™ control valve(s), and brine tank(s) using the Accumatic Brine System. For demand initiated regeneration, the units include a flow meter(s). BF series softeners can have regeneration initiated by time of day with the ERCt controller or by demand (accumulated flow) with the ERCd controller. Model numbers indicate the capacity, operation mode and whether the unit is demand or time clock initiated.

Composite Mineral Tank. The mineral tank shall be “polyglass” consisting of an inner shell of virgin polyethylene and an external shell of continuous fiberglass roving. Tanks shall be rated at 150 psi operating pressure, 120°F operating temperature with a 2½” -8 UN threaded top opening for the BF 30 and a 4” -8 UN threaded top opening for the BF 50 and 70. The BF 50 and 70 include a 2 ½” x 4” - 8UN reducer.

Manifold Assembly. The distributor shall be a 2½” Ø single point molded distributor head with 2½” of slotted length and a ½ inch female socket welded connection. The slots shall be 0.012” - 0.016” wide to retain mineral and the total slot area shall be equal to or larger than the unit pipe size. The distributor pipe shall be 1½” schedule 40 white PVC.

Resin Pack. The resin shall be sodium form polystyrene 8% divinyl benzene cross linked resin with clear spherical beads. Resin beads shall be 16-50 US Standard Mesh with a particle size range of 0.3 to 1.2 mm. The resin shall be clean and packaged in sealed plastic bags weighing 55 lbs or less. The bottom of this mineral tank shall be filled above the distributor with #20 graded washed flint gravel sieved between 1/8” and 1/16”

Brine Tank. The brine system shall be of the Accumatic™ high grid plate design. The brine tank shall be blow molded or rotationally molded HDPE, including a cover. The system shall include a float operated brine valve to control refill shut-off and refill flow rate. Brine volume is to be repeatedly accurate within 10% and not dependent on salt bed void space for brine volume. Brine draw is to be volumetrically controlled, not timed.

Brine Line Assembly (BLA). The brine tank is connected to the mineral tank with a Polyethylene tubing and Liquid-Tite Tube x NPT connectors. The brine inlet fitting to the valve is ½” MNPT and the connection to the brine tank matches the brine valve fitting.

Control Valve. The main control valve(s) shall be the Performa™ controlled with electronic controller to actuate the cycles of backwash, brine, slow rinse, fast rinse, and service. The control valve(s) shall be Performa™ 5-Cycle, 100 psi, multi-port control valve(s) with glass filled Noryl-NSF listed material, camshaft, drive motor assembly, and NEMA 3 enclosure (115VAC/60Hz). The valve shall be of a single camshaft design and not use multiple plungers or diaphragm valves. Hard water by-pass shall be available during all regeneration cycles. The drain line connection shall be ¾” NPT, female. Service C_v=6.5, Backwash C_v=4.0 (Valve Only). Water Temperature 35-100°F. Ambient Temperature 35-120°F.

Controller. The ERCt shall be up to 99-day regeneration frequency. Both the ERCt and ERCd Controllers shall have a calculated brine time when salt and resin quantities are entered.

Demand Regeneration. (optional) The BF series can be demand regenerated by using the ERCd Controller and the internal 1” Turbine Meter. The ERCd Controller shall be a 28-day variable reserve.

Funnel (2”). A plastic funnel is provided for adding media to mineral tank.

Operating Conditions. Maximum temperature shall be 100° F. Pressure shall be 25 to 120 psi.

Other items. A standard soft water soap test kit shall be provided. A complete set of instructions, including installation, loading, start-up, adjustments, servicing, and a parts list shall be provided with the equipment.

Qualifications. A company that has continuously manufactured water softeners for at least twenty (20) years shall construct this equipment.

Fiberglass Composite Mineral Vessels

FIBERGLASS COMPOSITE TANKS

Water King BF Series systems use fiberglass composite vessels with a fiberglass exterior and polyethylene liner.

SPECIFICATIONS

Standard Vessels. Composite tanks shall be 100% non-metallic construction, seamless, molded vessels with no welds or joints. The inner shell shall be constructed of polyethylene and the outside shall be wound with continuous fiberglass, roving to provide superior strength under pressures up to 150 psi. All tanks, vessels, and the materials used in their construction shall be accepted or certified by the Water Quality Association and ANSI/NSF Standard 44. Working pressure rating shall be 100 psi with a design factor of safety of at least 4:1. The tanks have a circular plastic base. Standard color shall be blue.

Note on temperature ratings. Composite polyester tanks with polyethylene lining with threaded fittings shall be rated at 120°F. Composite tanks with flanged fittings shall be rated at 150°F. Vinyl ester FRP tanks, without liners, with threads shall be rated at 150°F.

Residential / Light Commercial Application. The BF Bayou Series 3/4" and 1" plastic valves mount on a 2 1/2" threaded top opening.

703005 Single Point 3/4" Distributor.

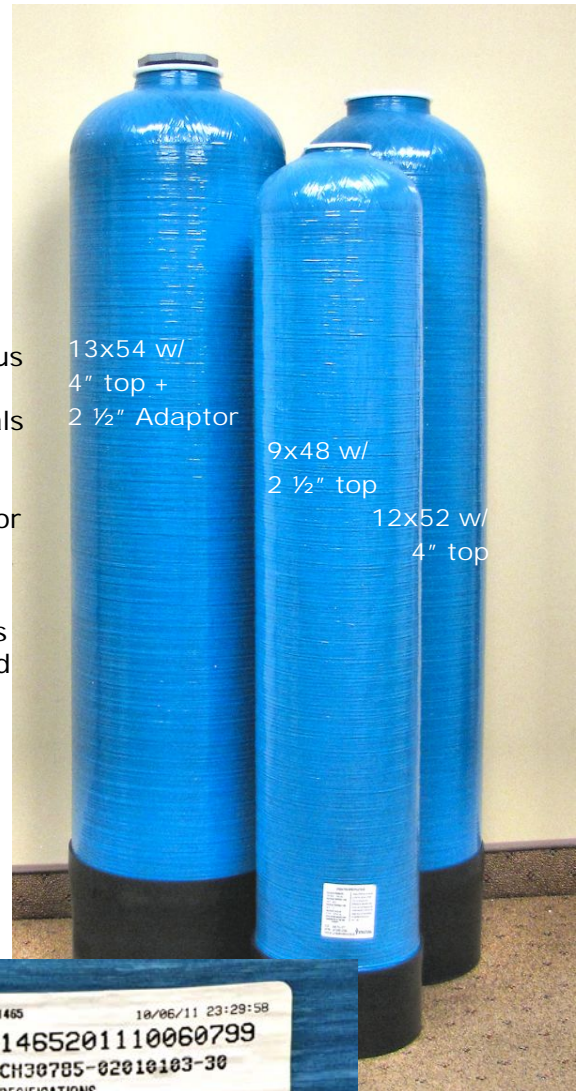

WK 100 Softener Resin

WK100 IS A MULTIPURPOSE, PREMIUM GRADE, STRONG ACID CATION EXCHANGE RESIN
WK100 IS SUITED FOR SOFTENING, AND CHEMICAL PROCESSING APPLICATIONS.

OPERATING CONDITIONS

Maximum Operating Temp:	250°F (120°C) in H ⁺ form 280°F (140°C) in Na ⁺
Form:	Shipped in Sodium Form
Resin bed Depth:	24"(600 mm) to 36"(900 mm)
Maximum Service Flow:	15 gpm/ft ³ (120M ³ /Hr/M ³)
Backwash Expansion space:	40 to 75%
Backwash flow Rate for 40 to 75% expansion at 77°F (25°C)	4 to 10 gpm/ft ² (9 to 25 M ³ /Hr/M ²)
Regenerant:	NaCl for Na ⁺ form.
Regeneration level:	3.7 to 10.0 lbs NaCl/ft ³ (60-160 g NaCl/l)
Regenerant concentration:	5.0 to 15.0% for NaCl
Regeneration flow rate:	0.25 to 2 gpm/ ft ³ (2 to 16 M ³ /Hr/M ³)
Regeneration time:	20-60 minutes
Fast Rinse:	At service flow rate
Slow Rinse:	At regeneration flow rate
Rinse Volume:	25 to 40 gal/ft ³ (3 to 5 M ³ /M ³)

INFLUENT LIMITATIONS

Free Chlorine:	Not traceable
Turbidity:	Less than 2 N.T.U

WK 100 RESIN CHARACTERISTICS	
Type	Strong acid cation exchange resin
Matrix Structure	Cross linked polystyrene (8%)
Functional group	Sulphonic acid
Physical form	Moist spherical beads
Ionic form	Hydrogen/ Sodium (KW100 is the sodium form)
Particle Size	0.3-1.2mm
Screen Size U.S.S (wet)	16-50
Total Exchange capacity	2.0 meq/ml (Na ⁺) form / 1.8 meq/ml (H ⁺)
Swelling (approx.)	Na ⁺ to H ⁺ 7%
Moisture content (approx.)	52% (H ⁺), 45% (Na ⁺)
Backwash settled density	50 to 52 lbs/ft ³ (800 to 840 g/l) in H ⁺ form 52 to 55 lbs/ft ³ (840 to 880 g/l) in Na ⁺ form
Operating pH range	0-14
Solubility	Insoluble in all common solvents
Shipping weight	0.82 Kg/l (approx.) in H ⁺ form 0.86 Kg/l (approx.) in Na ⁺ form

BILL OF MATERIALS			805061 18" x 40" BRINE TANK ASSY.		
ITEM	PART#	DESCRIPTION	QTY.		
A	505007	4"x36" BRINE WELL ASSEMBLY	1		
B	200145	3/8" OVERFLOW FITTING	1		
C	200190-1	18" x 5" HIGH SALT PLATFORM PLASTIC	1		
D	706026	3/8" BRINE VALVE W/ SAFETY FLOAT	1		
E	--	--	0		
F	200010-1	18" x 40" BRINE TANK WITH COVER	1		
G	400258	WATER KING DECAL - WIDE	1		
H	401237	OVERFLOW WARNING LABEL	1		
I	INST	USE 3/8" DRILL BIT TO DRILL HOLES			

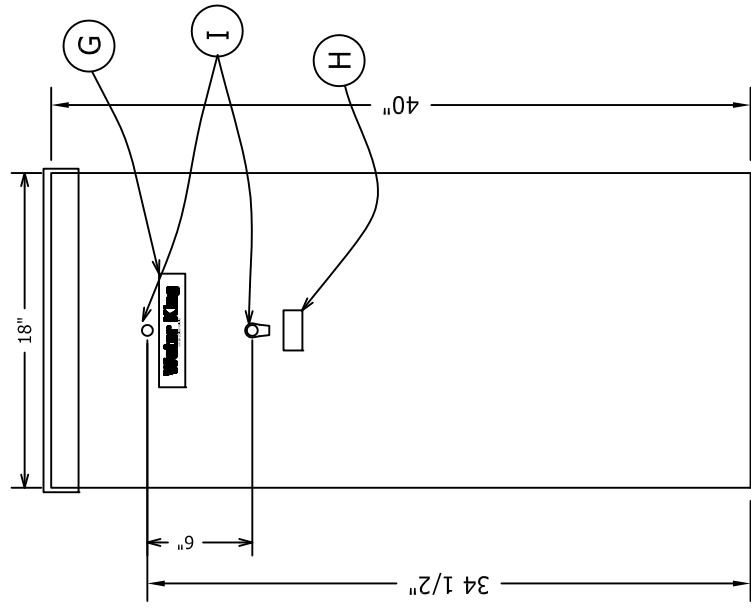
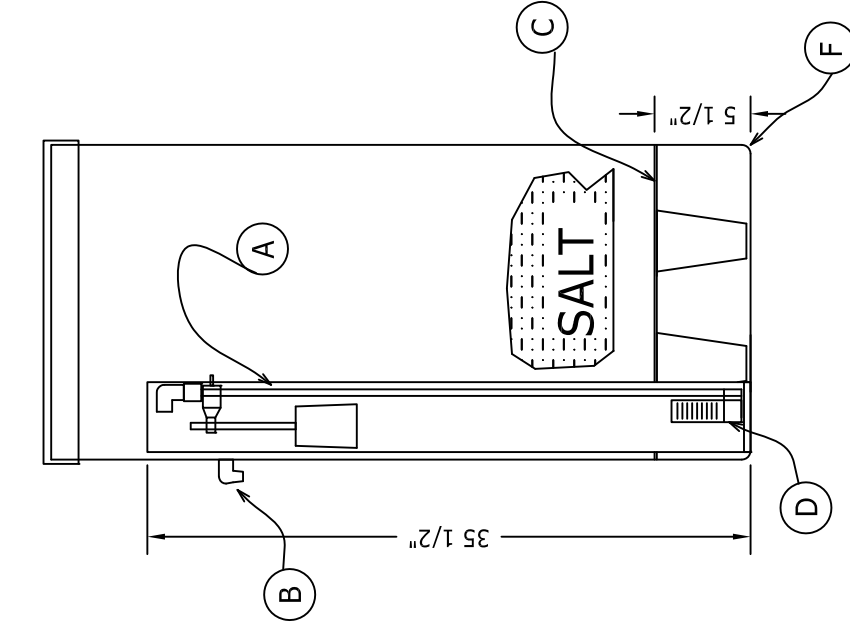

BY: No.	REVISION	DATE	CK'D
REL. 1	FOR FABRICATION	11/26/2013	JB
102 Charbonnet Rd., Duson, Louisiana, 70529, U.S.A.			Telephone: (337) 988-2360 * Fax: (337) 981-7922



805060		18" X 40" BF BRINE TANK- 5.5"SP	
ASSEMBLY DRAWING			
SCALE	DRAWING NUMBER	SHEET	
N.T.S.	805060	01 / 01	
www.waterking.com			

BF TUBULAR BRINE VALVE

TUBULAR BRINE VALVE

1. 1/2" Riser Tube (O.D.)
2. BF Systems have 3/8" Elbow to attach to a 3/8" Brine Line
3. Back up float assembly (safety float) that prevents overflow of brine tank if timed brine does not shut off.

The BF Tubular Brine Valve Features:

Air Check Valve avoids drawing air in the mineral tank during the brine cycle.

Provides brine draw and refill up to 1 1/2 gpm with 3/8" tee used on BF systems.

Fits in 3 1/2" or 4" brine wells. (BF systems use 4" brine wells.)

Components are air tested prior to shipment to ensure proper performance.

Clack Model 474 Brine Valve

Water King Part No. 706026

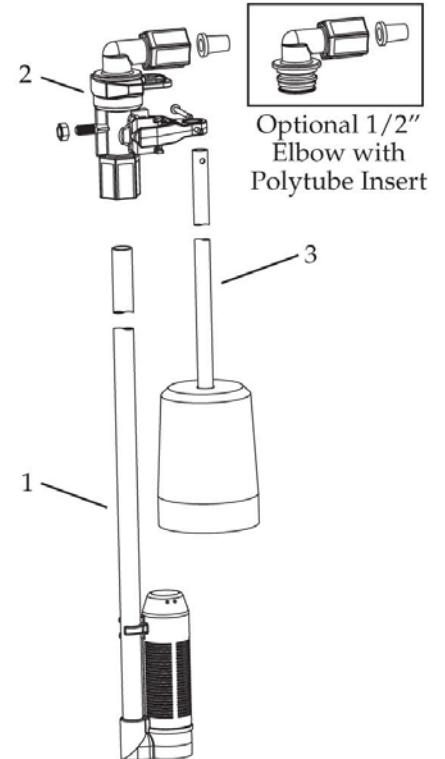

PERFORMA / LOGIX

Softener and Filter Valve / Controller



Control Valve. The main control valve(s) shall be the Performa™ controlled with electronic controller to actuate the cycles of backwash, brine, slow rinse, fast rinse, and service. The control valve(s) shall be Performa™ 5-Cycle, 100 psi, multi-port control valve(s) with glass filled Noryl-NSF listed material, camshaft, drive motor assembly, and NEMA 3 enclosure (115VAC/60Hz). The valve shall be of a single camshaft design and not use multiple plungers or diaphragm valves. Hard water by-pass shall be available during all regeneration cycles. The drain line connection shall be ¾" NPT, female. Service $C_v=6.5$, Backwash $C_v=4.0$ (Valve Only). Water Temperature 35-100°F. Ambient Temperature 35-120°F.

Controller. The ERCt shall be up to 99-day regeneration frequency. Both the ERCt and ERCd Controllers shall have a calculated brine time when salt and resin quantities are entered.

Demand Regeneration. (optional) The BF series can be demand regenerated by using the ERCd Controller and the internal 1" Turbine Meter. The ERCd Controller shall be a 28-day variable reserve.

CAT402.2

Features

- Single controller for any configuration
- Softeners and filters
 - Twin alternating
 - Twin parallel
 - Single tank
- Remote regeneration start
- Multi single tank lockout capability
- Easy 3-step program control
- Fully programmable or manual operation
- Simple piping installation
- Flow meter on each valve
- Simple, economic electronic demand (volumetric)
- Calendar override
- 12-volt operation
- 28-day variable reserve
- High efficiency regeneration sequence
- Automatic capacity calculations
- Fully programmable cycle times
- Salt setting in 1-pound increments

